



JENCOLOR Color Sensor ICs

1 General

More and more applications that have up until now required traditional filament lamps to function as lightsources increasingly convert to LEDs today. This is not only due to the many times longer lifetime of a LED, but also to the fact that LEDs provide a variety of engineering and functionality options which are impossible to achieve, or can only be achieved at considerable effort, when using filament lamps.

A product involving different colors can be cited by way of a simple example. No color filters will be required in this case. The aperture angles of such lightsources can easily be varied without having to introduce any additional optics.

Since LEDs are known to be easily and reproducibly controllable in terms of their intensity, they also facilitate applications of a more complex nature. These include, for example, the controlled generation of "random" colors with the help of RGB LEDs, but also operation control of white-light LEDs as a special purpose.

These new LED applications create new requirements on the test and metrology technology. Even for consumer electronics with clearly lower quality standards (for LEDs), LED testing has become an indispensable part of the manufacturing process if only to ensure their correct placement on the circuit board.

For automobile and aviation applications, the latest requirements are so high that costly laboratory equipment such as spectrometers for color and intensity analysis has to be employed in order to control or monitor LED illumination sources and achieve test results in accordance with official standard requirements.

In the case of cost-sensitive mass products with short cycle times, spectral-based measuring devices can only be integrated into a running production plant if substantial efforts and expenditure are invested. Typically, the final product itself renders the use of standardized measuring equipment and procedures impossible, because of its high packing density.

Based on JENCOLOR color sensors from MAZeT, PREMOSYS has developed and sold devices for three years. The PREMOSYS product line is primarily intended for mass production environments, where LEDs have to be tested and evaluated for a diversity of quality requirements in an expeditious and highly reliable manner. Today, their devices are already successfully operating in many branches of industry. Examples include consumer electronics, the food industry and last, but not least, the automobile industry.

The following chapters describe the problems and proposed solutions in connection with applications involving stricter quality requirements. A trial version for the development of a fully controllable and adjustable lightsource with JENCOLOR color sensors as its core part is derived from the practical findings explained below. PREMOSYS as a product and system supplier offers custom-tailored services to create such lightsources.

Color Sensors To Control and Qualify Lightsources

2 Problems in Connection with LED Operation and LED Testing

With very many products, the requirement is for all LEDs to be "consistently bright and colored". Typically, there is a special working practice with luminous intensities exactly specified in units of a cd (candela). As a rule, the various LEDs are classified by the manufacturer. These classifications refer to the available wavelength and intensity ranges. Usually, the tolerances on wavelengths are much wider than those on intensity.

2.1 LED-Induced Variances

The tolerance ranges on intensity create the first kind of problems. Frequently, when ordering a given type of LEDs of a particular class, one has no other choice than to accept delivery of an additional lot of LEDs assigned to adjacent classes. This implies that the manufacturing process must be prepared to handle two LED types. In addition, many manufacturers divide their intensity classes into sub-classes

Despite this inherently precise classification, the tolerances on variance which have to be specified for luminous intensity may in some cases be well over $\pm 20\%$. The figure below provides an extract from the data sheets of a manufacturer - OSRAM Opto Semiconductors [1].

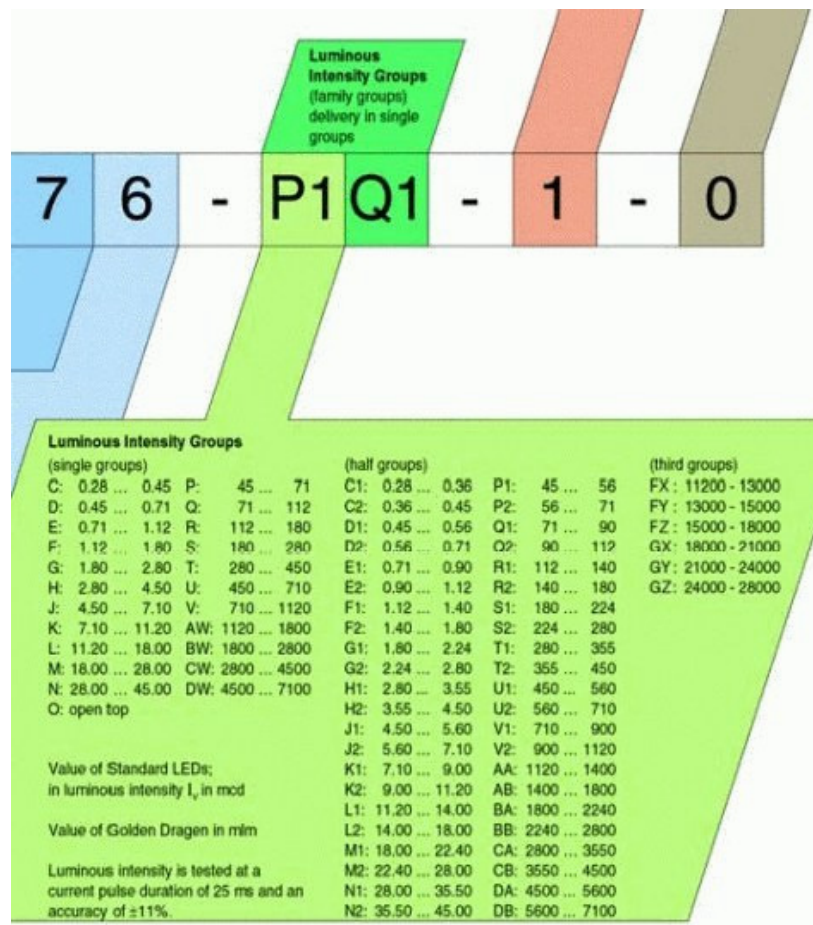

Figure 1: Extract from data sheets with intensity classes

Color Sensors To Control and Qualify Lightsources

Given that the human eye is able to perceive intensity variations between two objects of more than 1% [2] color variances of $\Delta E > 3$, such variations in intensity cannot be ignored even with selected LEDs. For this reason, all applications with "eye-precision" quality requirements inherently call for LED testing.

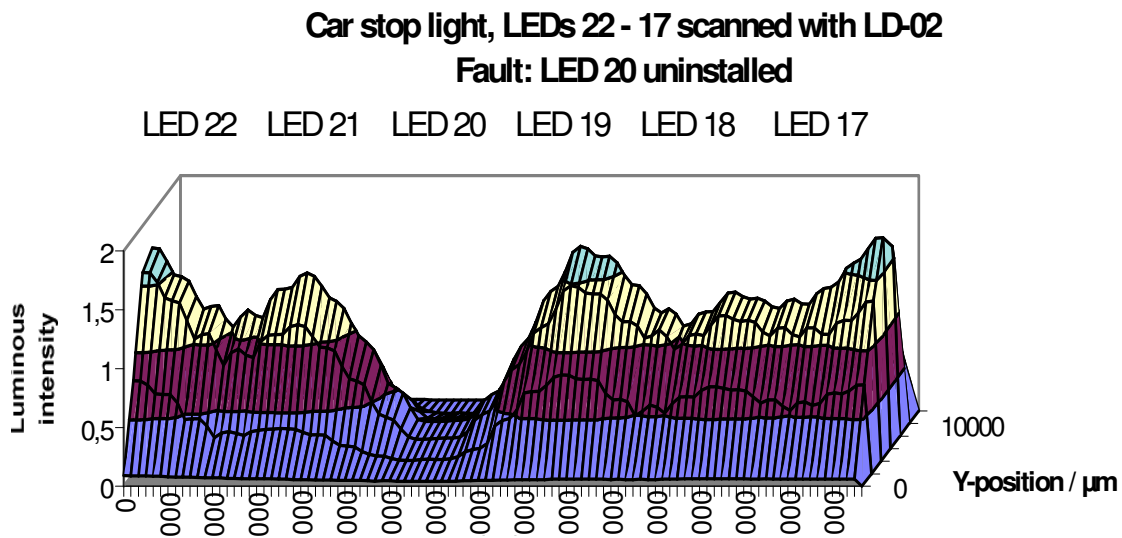
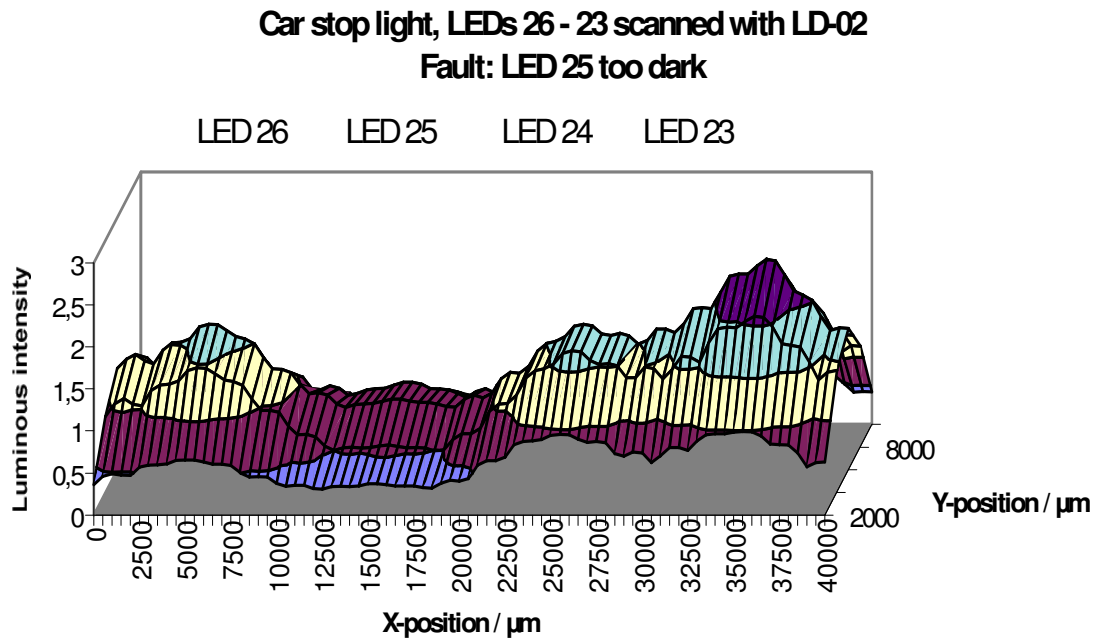

Figure 2: Test results achieved for high-mounted car stop lights with color sensors

Further problems can be observed with, including but not limited to, SMD LEDs, the prevailing type in today's applications. Positional variances are already created by LED mounting. During subsequent soldering, the LEDs may "swim up", some get "tilted" or even detached. The final product must be expected to have a placement error of some tenths of a millimeter, which renders them irreproducible.

Color Sensors To Control and Qualify Lightsources

During subsequent component testing, the test optics for a particular LED is typically fixed so positional variances of the LED can only be compensated to some extent. The following Figure shows the normalized graphs for change in intensity. They have been obtained using standard optical fibers of 1 mm fiber diameter, which are available as low-price mass product. Additionally, it represents two optical input modules of a greater size that have been built to special custom order.

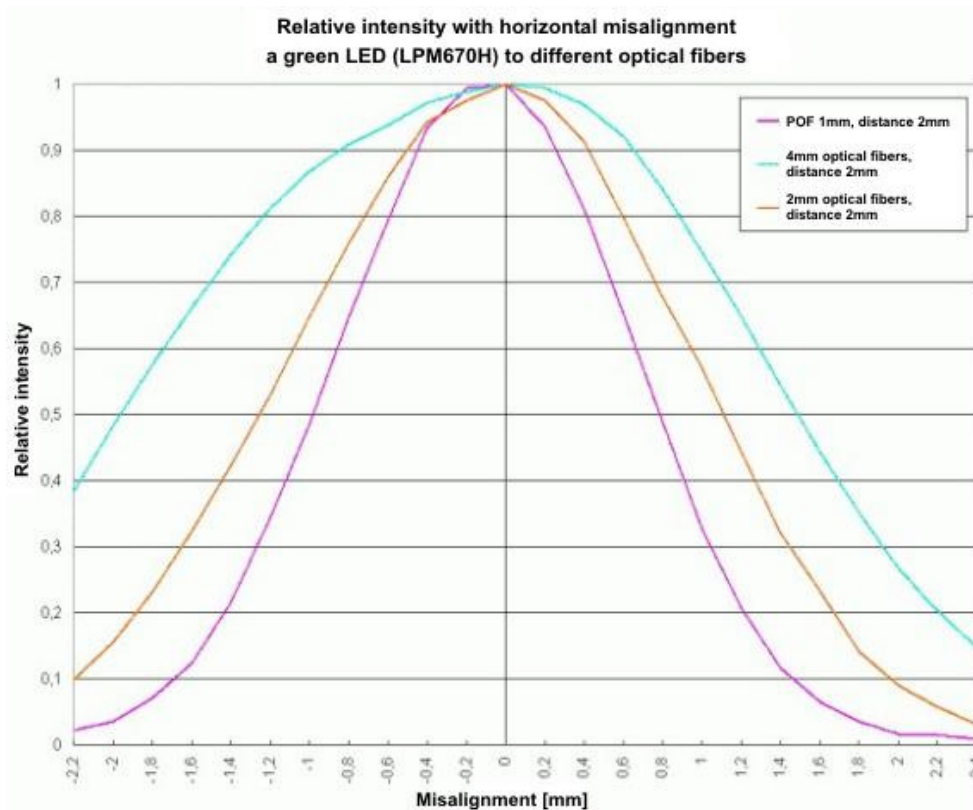

Figure 3: Influence of LED positioning accuracy on intensity measured with different optical fibers

A LED "reversal" will lead to additional metrology errors. Altogether, inherent product variances must be expected to induce a further minimum amount of $\pm 10\%$ in measuring error.

2.2 Variances Induced by the Test Setup

Test setups can be subject to a certain temperature sensibility. Depending on the wiring diagram, this may be directly due to the photo diode, or in the case of signal currents close to dark-current level, result from down-line analog circuitry parts. Phenomena of this kind can be minimized through appropriate circuit designs. These are matched to the particular application and cost requirements.

The dark currents of photo diodes produce offset errors and grow with rising temperatures. At the same time, they also induce gain errors in down-line circuitry parts. The following Figure illustrates (by way of example) the amount of intensity errors that would be obtained using a test system with no temperature compensation capability. It also contains the ultimate graphs after temperature compensation by the same system.

Color Sensors To Control and Qualify Lightsources

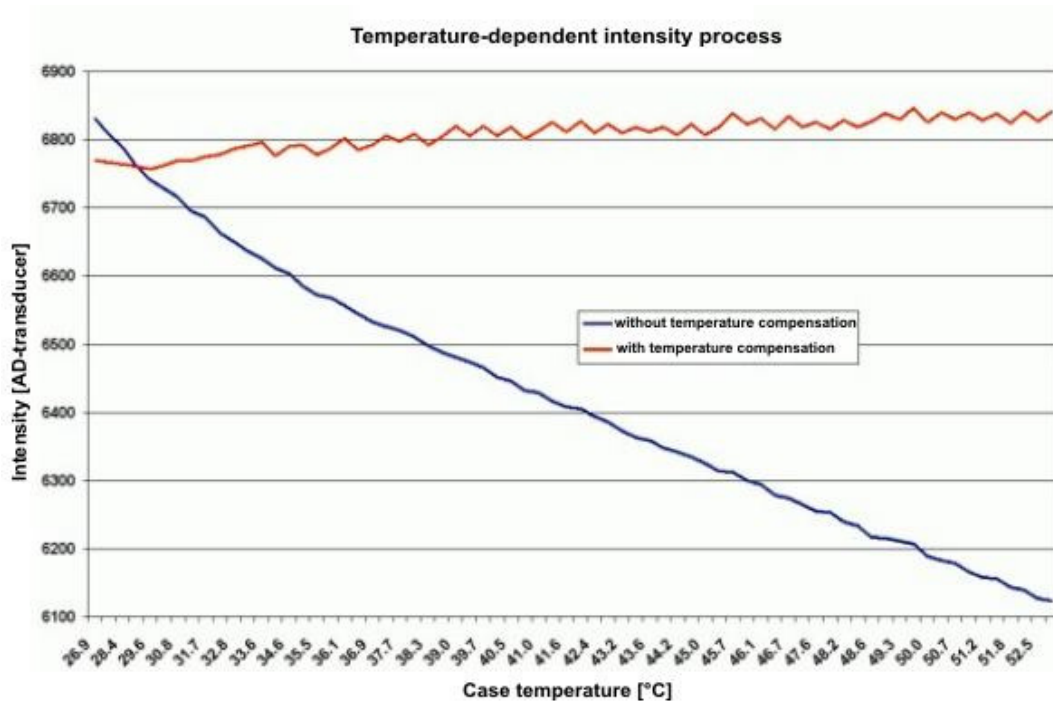

Figure 4: Faulty measurement due to temperature drift

Further variances may occur due to mechanical error sources, for example, if a product is to be reproducibly fixed for testing in identical places of an illumination cone. This may lead to errors of a type as shown in Figure 3.

2.3 Summary of Expected Variances

Depending on the test arrangement, a thermally non-compensated system must be expected to output a signal current level with up to $\pm 5\%$ measuring errors (approximately) in each case.

Non-uniformities in LED brightness may easily correspond to $\pm 20\%$ even for selected LEDs. This is added by mechanical variances resulting from non-conforming placement of the LED chips in their respective packages. In a realistic assessment, these may be assumed with $\pm 10\%$.

This means that a linearly (proportionally to intensity) working measuring system with no special precautions is likely to deliver test results that may differ by as much as $\pm 35\%$ for certain products. Another error source are the features of the selected optical fiber. Notably with POF fibers, which are typically reprocessed by the customer himself, the light inlet and outlet faces provide no optimal performance. This, in turn, creates a more or less strong attenuating effect that remains constant so it can be treated as a calculable offset compensation value.

Color Sensors To Control and Qualify Lightsources

3 Problem Solutions

3.1 LEDs

A large number of component manufacturers compensate LED variations by integrating selected series resistors with each delivered sub-class. In such cases, final acceptance must ensure that each LED is configured with the correct series resistor. This approach allows LED variances to be reduced to about $\pm 10\%$.

Some manufacturers use their incoming goods office to perform an extra preselection of LEDs, an operation that adds more efforts to the manufacturing of a product, but does not replace final acceptance.

Mechanical faults and irregularities cannot be compensated by way of preselection.

3.2 Test Setup by the Example of PREMOSYS Products

Since misplacement can hardly be avoided or counteracted where SMD LEDs are employed, absolute light intensity measurement with an ultimate output result in candelas will only make sense if a reduction in misplacement or mispositioning can be achieved with the help of a diffusor foil on the light input side. As with many other metrologic tasks, a relatively accurate test apparatus is much more important. The same lightsource is to always provide identical measuring results.

One possible way to achieve this is by individually subjecting PREMOSYS products to an automated 24-hour calibration run in a heatable cabinet. A specific correction graph can thus be determined for each measuring device. Equipped with integral temperature sensors, it will be able to provide optimal offset and gain compensation for any given operating temperature. The result is shown through a red graph in Figure 3. This makes it possible to achieve measuring errors below $\pm 2\%$ through the entire temperature variation range. With a temperature range of $\pm 5^\circ\text{C}$, the error margin is even clearly below $\pm 1\%$. For the human eye, this is an unperceivably small amount!

In addition to thermal compensation, the colors are adjusted to a defined broad-band lightsource. This balancing operation guarantees that all products will output identical color data, working from this lightsource.

Based on a test setup that provides reproducible results also in terms of mechanical features (notably, with regard to the "optical" positioning of light conductors), the amount of measuring errors can thus be reduced to $\pm 10\%$ at reasonable effort.

Where the nature of a product allows to, measuring errors as a consequence of positional variance of SMD LEDs can be further minimized by introducing a different input optics so even densely packed components may well reach measuring errors smaller than $\pm 5\%$ at the expense of additional optics designs. The following Figure shows a comparison of such a special optic design and a standard plastic fiber. This special optical design unit has a mounting diameter of as little as 7 mm.

Color Sensors To Control and Qualify Lightsources

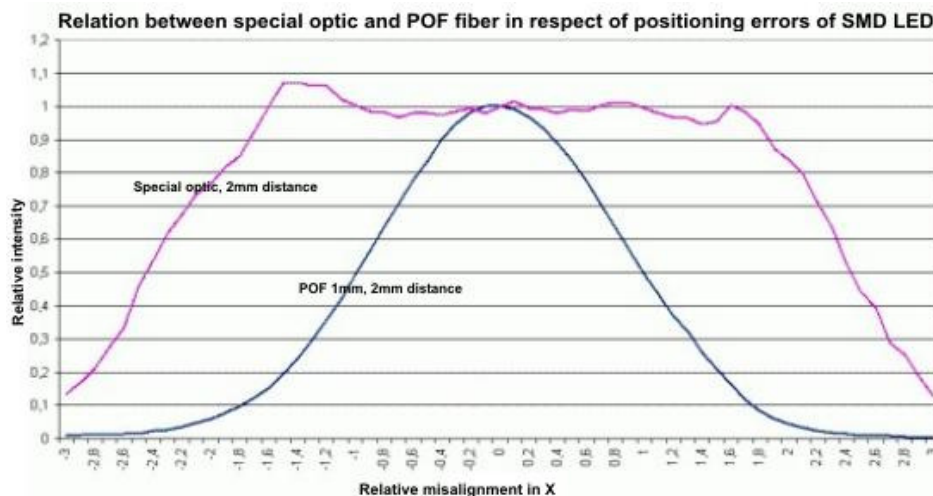

Figure 5: Compensation of measuring errors resulting from misplacement of SMD LEDs with special optics design

4 Calibration

If all precautionary measures described in chapter 3 above have been incorporated, including also series resistors for LED matching (*without any preselection of LEDs prior to mounting!*), mass-volume products may be manufactured with a total intensity variation smaller than $\pm 15\%$.

Where products have to be additionally classified based on the result of final acceptance testing, the achievable accuracy is as high as $\pm 5\%$ residual error. However the same variation must also be expected in the event of additional efforts invested into preselection.

The following passages will discuss: "*What luminous intensity does a product have?*" notably, in the case of applications where even significantly smaller errors in color analysis cannot be ignored. This is complemented by the question: "*What color position does the product have after all?*"

Both issues can be solved by calibrating the results of measurement against a reference (master) product under laboratory conditions. For example, information about the luminous intensity can easily be obtained in units of an andela (or luminous density in cd/m^2) by multiplying the non-dimensioned measuring results of a test apparatus with a factor that follows from the gauging of an identical product in a laboratory. This provided, any variances that are inherent in a production process can be traced back to these units.

A clue to the color position can basically be obtained in the same way for single-color LEDs, except that the color tolerances for such lightsources can be calibrated. However, to perform this calibration, a spectroscope is needed for reference in any case.

For multi-color LEDs, especially white LEDs, such a "product-comparing" calibration becomes a more costly matter. In such cases, it is possible to obtain a concrete standard-compliant color statement already from the measuring equipment. The procedure to perform this calibration is described in example [3].

Color Sensors To Control and Qualify Lightsources

5 Application of a "Smart" Lightsource

The following describes a proposal how to build such a lightsource. The work task to achieve this can be formulated as follows:

1. The lightsource should be able to cover a fairly broad range of colors and its setpoint inputs should comply with a standard-defined color space.
2. The lightsource includes a self-stabilizing device and takes account of any error source that can bring about a falsification of the resulting color.
3. The ambient light has to be compensated.
4. The module should be field-bus compatible and strongly miniaturized.
5. Multiple modules must provide identical behavior in relation to each other. Identical setpoint inputs should lead to identical results.
6. The module should be modularly extendible and cascadable.

5.1 Block Diagram

There are two possibilities to obtain a lightsource that covers a broad color spectrum: an RGB LED or three single LEDs, one for red, one for green and one for blue. The latter version is more appropriate where an application requires a high brightness of a level that cannot be reproducibly achieved with compound RGB LEDs to such an extent up until now.

- Regardless of the selected type of LED, there must be electric circuitry capable of controlling the individual colors in a consistent manner. With uncontrolled systems, this function is inevitably handled by a triple stabilized power supply, because otherwise no constant brightness can be guaranteed due to a certain temperature rise in the LEDs. For the proposed lightsource, a PWM driver concept appears suitable, since changes in the generated light are compensated by the module itself. A control scheme of this type simplifies the module design as a whole.

The setpoint inputs come from a micro-controller which is also able to create the PWM for LED operation control and provide various communication ports.



Figure 6: MAZeT JENCOLOR ICs

Color Sensors To Control and Qualify Lightsources

To register the actual value, a JENCOLOR three-range color sensor from MAZeT is used. Of the available types, the MCS3AS in a small SO8 SMD package or the integral MCSiAT in a TO5 package [4] appear to be highly suited to achieve a miniaturization of the system. The sensor signals are amplified and pass through a downline filter. It suppresses any high-frequency portions that have been created by the PWM driver part. The three color signals are then digitized and can thus be used by the micro-controller as the actual value for internal feedback control.

The design further integrates a temperature sensor that is thermally closely coupled to the LEDs and the color sensor. The temperature sensor's output addresses the micro-controller to be used for temperature compensation. Available micro-controllers include both a digitization and a temperature sensing functionality.

For communication with a master-control Host, many versions are conceivable. A very simple one can, for example, be organized at affordable cost, using a standard RS485 interface with a very simple protocol and virtually any micro-controller, while other bus systems typically require specialized versions. According to standard requirements, up to 32 users may connect to an RS485 bus system. There are, however, semiconductor manufacturers providing optimized drivers that allow for a considerably greater number of users. Yet to retain the possibility of linking to other field bus systems, an additional single module is required that will act as a bridge between the two bus systems.

The following Figure shows a block diagram to realize a controllable feedback-looped lightsource of a type that could be fit for practical use. Depending on the application requirements on parameters and functionality, alternative components can be imagined and custom designs be integrated. You are advised to address PREMOSYS on these issues. An established device developer and manufacturer with many years of experience, the company will be glad to help you with proposals for a suitable engineering design solution.

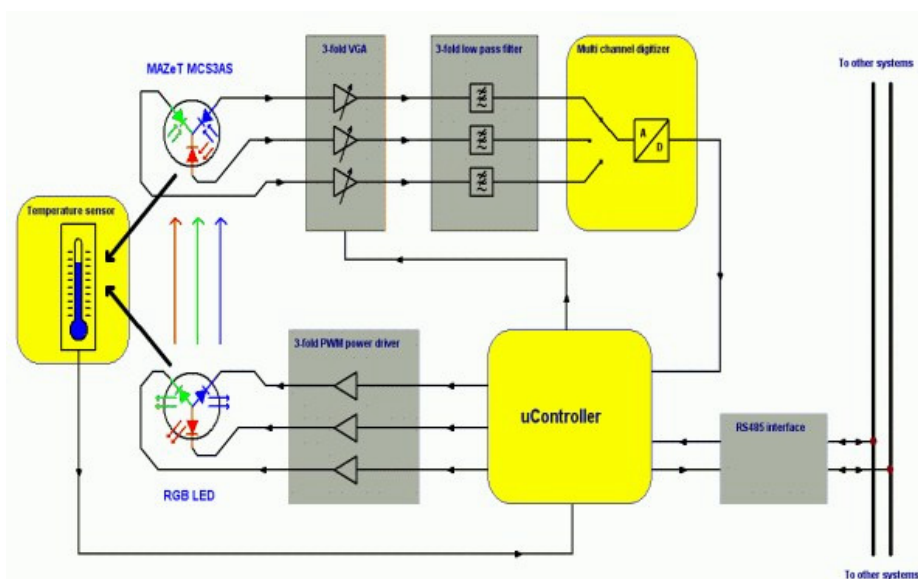

Figure 7: Block diagram of a controllable feedback-looped lightsource

Color Sensors To Control and Qualify Lightsources

5.2 Calibration of Such a Module

Calibration is performed under two aspects.

Firstly, its purpose is to compensate internal offset and gain errors. This is achieved by subjecting the module to a calibration run with ambient temperatures varying during several hours.

Secondly, a spectrometer with photometer is used to adjust the module to a standard to be defined. This calibration ultimately delivers the correction values described under [3] above for the micro-controller to autonomously convert a setpoint input into the correct color.

5.3 Compensation of Ambient Light

As the module represents an illumination component (according to Figure 6), other lightsources introducing stray or parasitic light portions must be assumed to be present in the direct vicinity. Such stray light portions can be compensated with suitable software in the micro-controller, e.g. by what is referred to as *Pulsing*.

This is done by turning the effective LEDs off at regular intervals for measurement of their actual state (=ambient light). The results thereof can then be simply used as offset inputs. If digitization works fast enough and the filter delays are small enough, this process may run at a speed that cannot be perceived by the human eye any more.

6 Summary

With recent developments in engineering and technology, the requirements on LED-based lightsources have also grown. Whether integrated in displays, replacing conventional illuminators, operating as a lightsource or as signal devices – LEDs are more and more applied in all branched of industry and commerce. Even so, the steadily increasing luminous intensity of LEDs is still faced with the problem of continuing or resulting actual variances that call for comprehensive LED testing or correction control measures as part of the production process or during operation. On the one hand this is due to rising expectations in terms of engineering design, surface finish and color consistency of industrial and consumer products. On the other hand, it is also a consequence of the steadily rising quality standards in man-machine communication. For quality assurance or operating needs, users typically content themselves with a sufficiently accurate detection ("eye-accurate detection") of color differences, renouncing the use of absolute numerical chromaticities in an effort to achieve the required components at low cost and with good integration properties.

In the area of media applications, reproductions are required to be true-to-perception, i.e. provide a "True Color" impression. which amounts to standard-compliant color measurement with accuracy levels as necessary in the various application scenarios.

Color Sensors To Control and Qualify Lightsources

With the help of JENCOLOR Sensor ICs such measuring and control systems can be perfectly implemented for LEDs to meet "True Color" level. Because of the small size of detector ICs, solutions of this kind can be arranged directly and compactly close to the lightsource (LED) or be realized via optical fibers. The sensor ICs contain precise high-grade color filters that develop no aging effects, i.e. need not be recalibrated during operation.

In view of the boundary conditions described above, entirely new and custom-tailored design approaches are becoming realistic for "Measuring and Controlling Lightsources" applications in a compactness and universality that used to be impossible or only partly possible in the past.

PREMOSYS builds novel measuring and control systems, based on true color sensor ICs from MAZeT. It offers these as its own standard products or uses them as a basis for custom-engineered solutions.

7 Literature Sources

[1] http://www.osram.convergy.de/upload/documents/2003/01/14/13/57/SFC03_LED.pdf

[2] <http://www.poynton.com/PDFs/GammaFAQ.pdf>

[3] JENCOLOR Sensor ICs AppColorMeasurement.pdf, Application Document
MAZeT GmbH, Jena – www.MAZeT.de

[4] JENCOLOR Sensor IC Data Sheets
MAZeT GmbH, Jena – www.MAZeT.de

8 Contact



PREMOSYS GmbH
Vulkanstrasse 2
54578 Wiesbaum
Tel.: +49 6593 998682
info@PREMOSYS.com
www.PREMOSYS.com



MAZeT GmbH
Göschwitzer Straße 32
07745 Jena
Tel.: +49 3641 2809-0
sales@MAZeT.de
www.MAZeT.de